

**TRT™ Rail Base Racking System TRT™ 02**



# *Assembly Instructions*

Version 3.1

03/17/2025

## Table of Contents

1. General safety information .....	3
2. Test and certification.....	4
3. Tools overview .....	5
4. Component introduction.....	6
5. Roof inspection and system layout.....	9
6. Installation step .....	13
6.1 Installation of cast Aluminum base.....	13
6.2 Installation of cast Aluminum base.....	15
6.3 Installation of solar mount rail.....	17
6.4 Installation of solar panel .....	19
6.5 Installation of skirt.....	21
6.6 Installation of ground lug and bonding jumper.....	25
6.7 Installation of micro inverter racking.....	27
Thank you .....	29



## 1. General safety information

- Prior to installation, ensure that the product complies with on-site static loading requirements. For roof-mounted systems, the roof load-bearing capacity must always be checked meet the requirements.
- During installation, the construction site must be blocked from the public to prevent fall injuries. At least one copy of the installation instructions must be available at the installation site. Installation work may only be carried out by adequately trained and qualified installers.
- Qualified personnel are those who have skills, knowledge and training in the installation of PV mounting systems necessary to follow this manual in order to safely use the required tools and to carry out the required procedures. They must be physically and mentally fit and at no time are they allowed to perform installation work while under the influence of drugs, alcohol or even drugs.
- The installation team must distribute safety helmets, gloves, safety ropes and other equipment to each installation worker to ensure that each installation location is equipped with more than two installers for timely rescue in the event of an accident.
- These installation instructions describe the procedure for installing the product. Read these assembly instructions carefully before starting the assembly. Follow the instructions carefully to ensure the correct installation of the product.



- Failure to follow our general safety and assembly instructions, Top Rack Technology Inc. (TRT™) from any liability for resulting defects or damage. Warranty is void in such cases.

## 2. Test and certification

The bracket design complies with the following test and certification:

- UL 2703 CERTIFIED
- PE CERTIFIED
- FIRE TEST
- Grounding Test



## 3. Tools overview

### ◆ Power tool with Torque

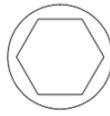
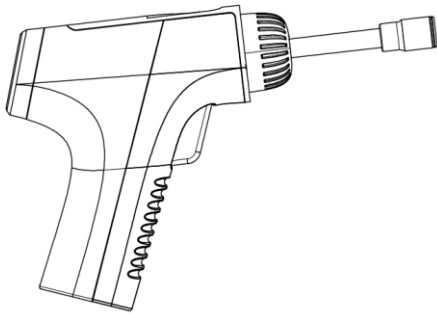

With 1/2" or 13mm socket

### ◆ Tape measure

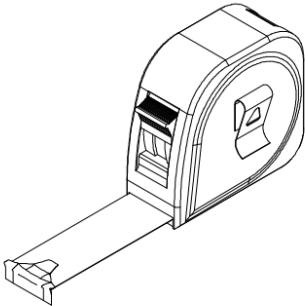

### ◆ Chalk line tool

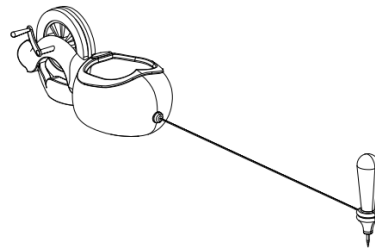

### ◆ Chalk

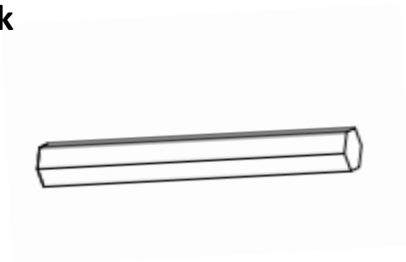

## 4. Component introduction

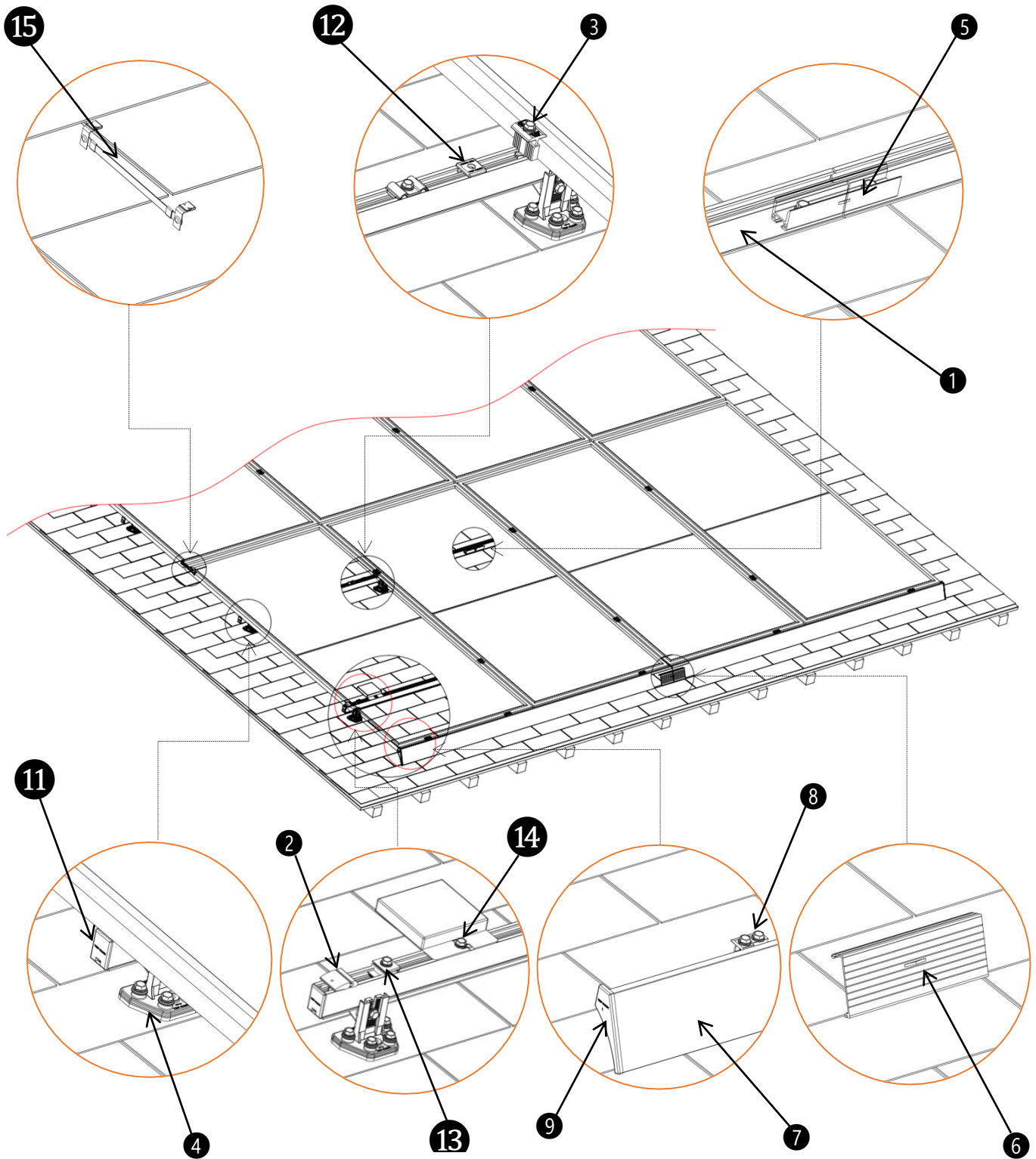

① Rail | A188-4270

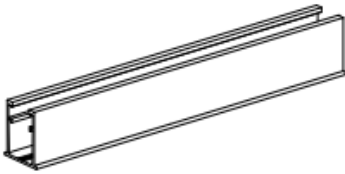

② Hidden End clamp | 3010237

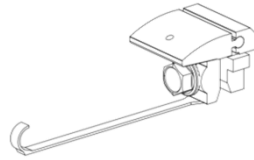

③ Mid clamp | 3010355

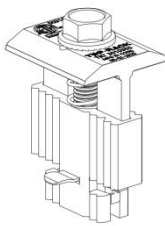

④ Cast Aluminum Rail Base | 3010368

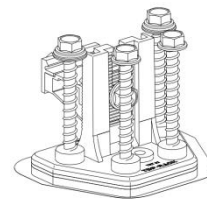

⑤ Rail Splice | 3010404

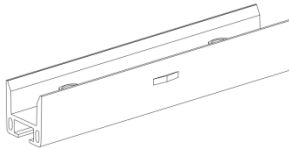

⑥ Skirt Connector | 3010405

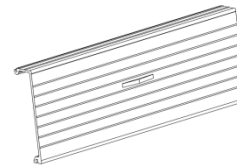

⑦ Skirt | A197-2300

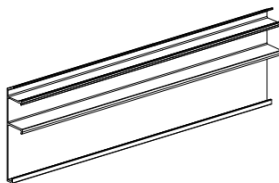

⑧ Skirt clip | 3010363

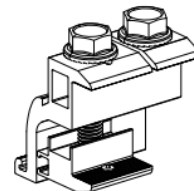

9 Skirt Cap-L(108)&1040108



10 Skirt Cap-R(109) | 1040109



11 End cap | 1040088



12 Wire cap | 1040089

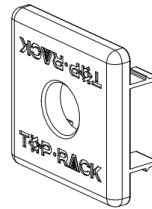

13 Ground lug 1 | 3010407

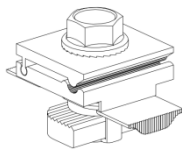

14 Micro Inverter Racking 1 | 3010167

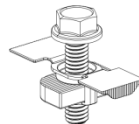

15 Bonding Jumper | 3010406

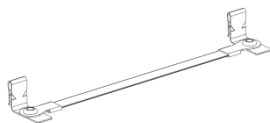

## 5. Roof inspection and system layout

- Measure the dimensions of the roof, make sure after the system is installed, there is at least 6" from the roof ridge, and 20" from eaves
- Measure the spacing between rafters, make sure the width of the rafter is not smaller than 2"
- The installation must ensure that the gap between the system and the roof can allow for ventilation, drainage, fire protection and moisture resistance. After installation, places that are prone to moss and dirt should be cleaned regularly.
- Survey the actual length, width, angle, rafter span etc. of the roof.

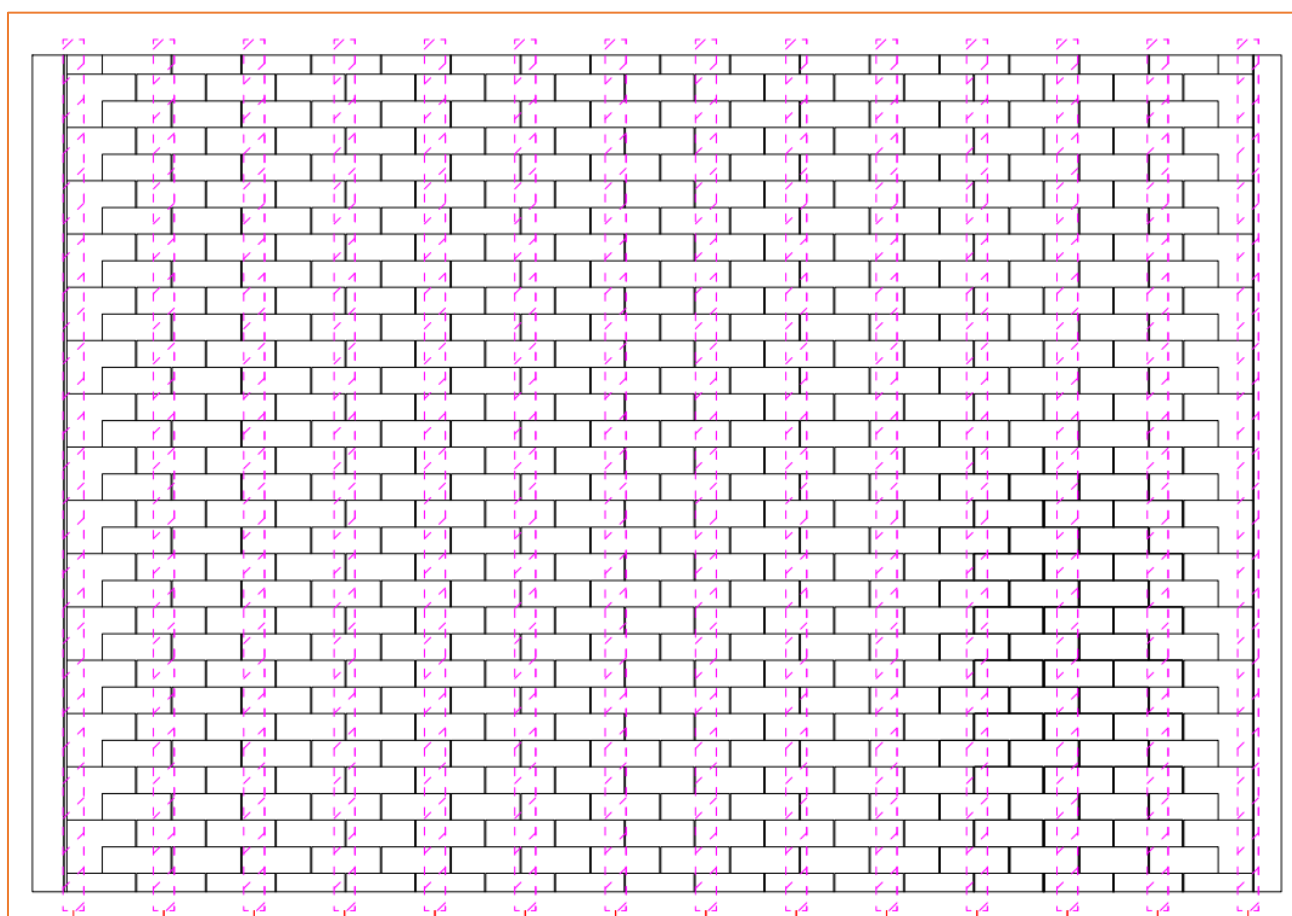

- Draw the rafter locations on the layout plan to identify where the roof accessories can be installed. The span between each installation location should follow up the PE Letter of each States.
- Transfer the layout plan to the roof in proportion using a marker pen or chalk,
- Note: The rails of solar panel can be laid out parallel to the rafters or perpendicular to the rafters.



When installing the module vertically (Rails is perpendicular to the rafters).

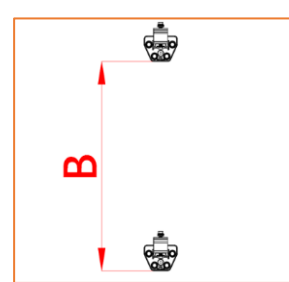
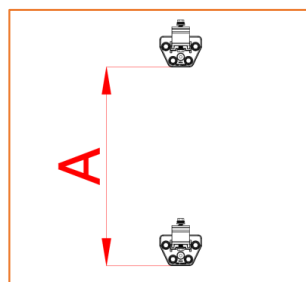
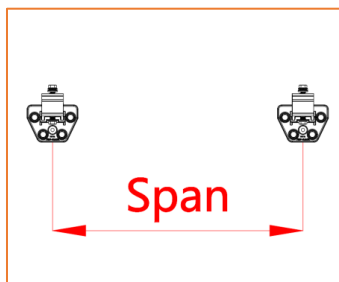
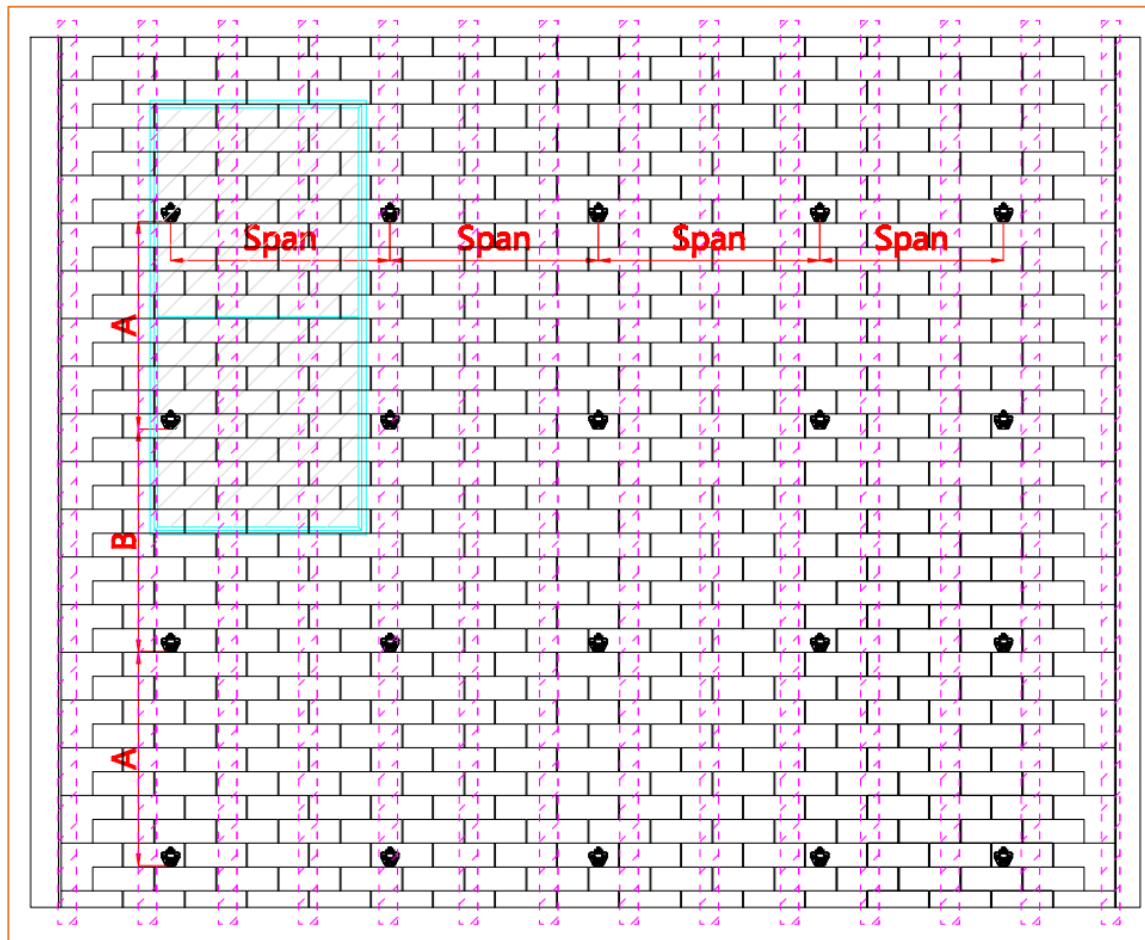

Span=the data shows in the table in page 9

A= 1/2 long frame length+/-5"

B=A+0.5"



When installing the module horizontally (Rails is parallel to the rafters).

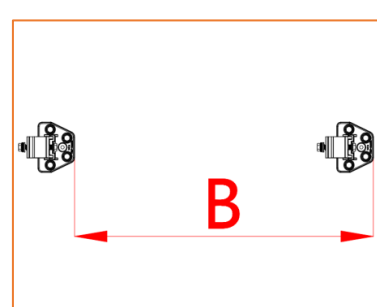
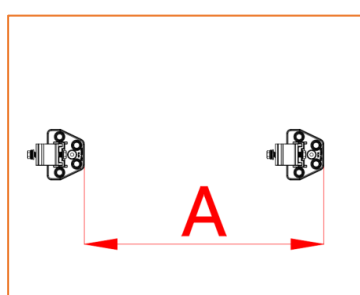
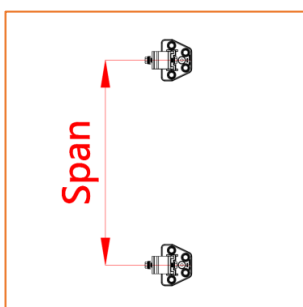
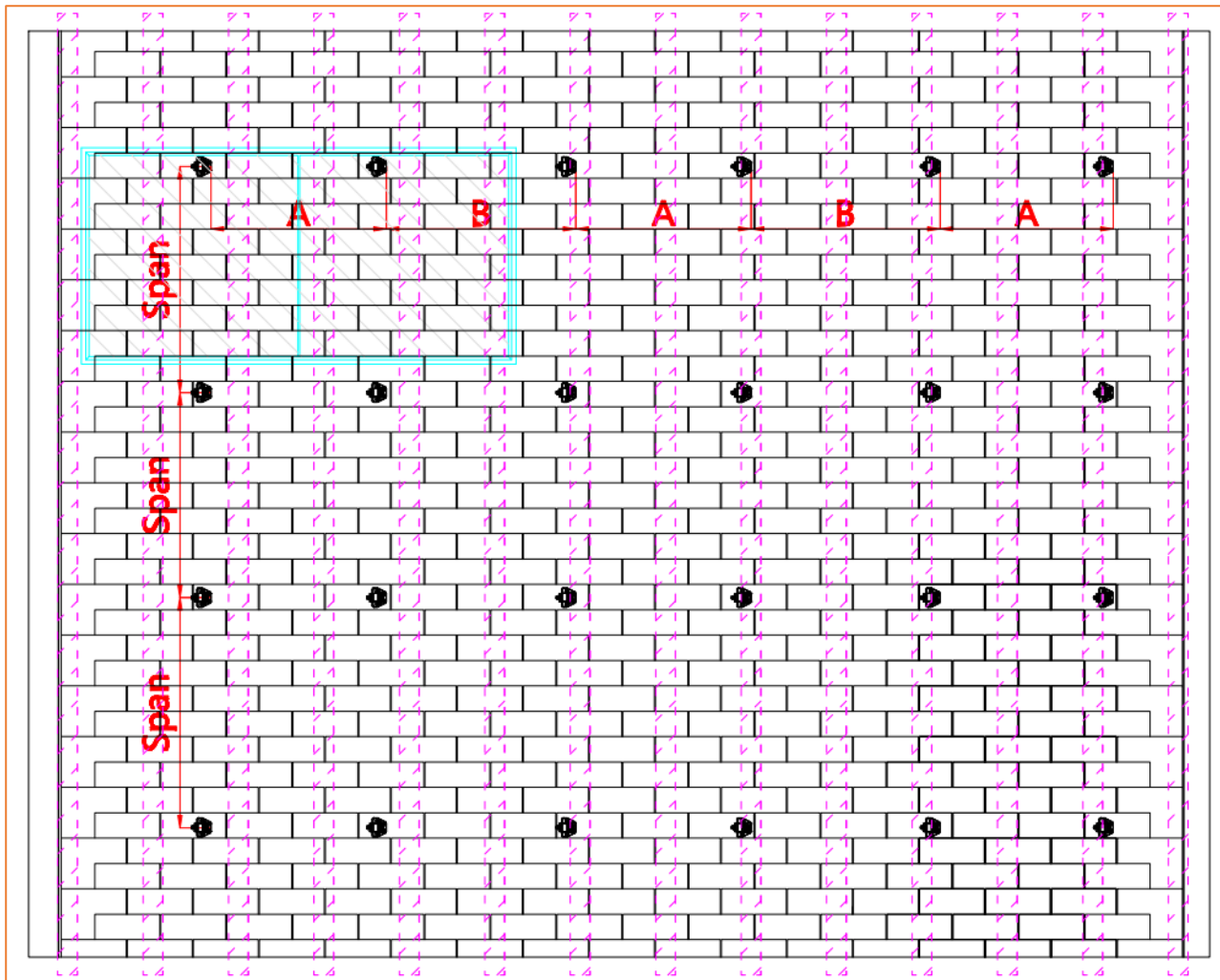

Span=the data shows in the table in page 9

$A = 1/2 \text{ long frame length} \pm 5''$

$B = A + 0.5''$



## 6. Installation step

### 6.1 Determine the base installation position

- ① Tap the roof with a hammer to find the location of the rafters, depending on the layout, some bases will be installed above the beams and some will be on the deck.

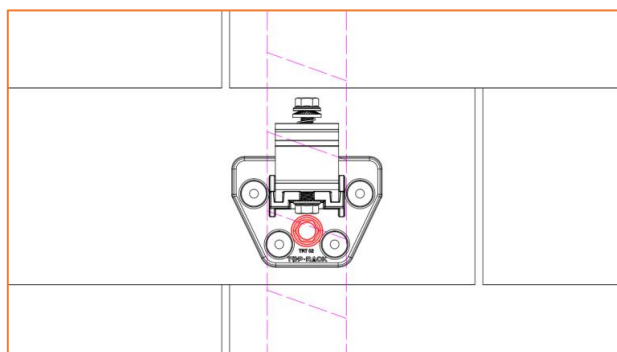

#### Install on rafter:

When the mounting position of the base is exactly on the rafter, then only one lag screw (the central mounting hole) is needed to secure the base. As the Images show.

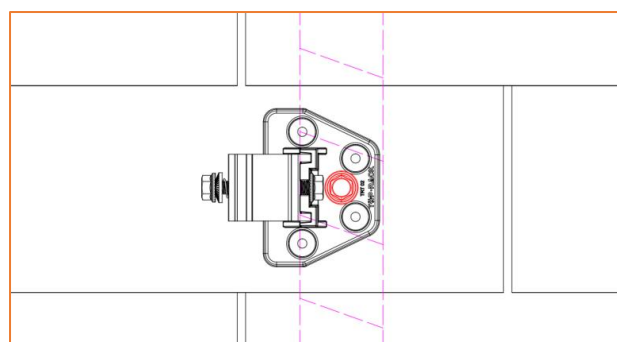

If only a part of the base on the rafter, then move the base slightly to make the central mounting hole on the rafter, then use one lag screw to fix the base. The movable distance of the base is 1".

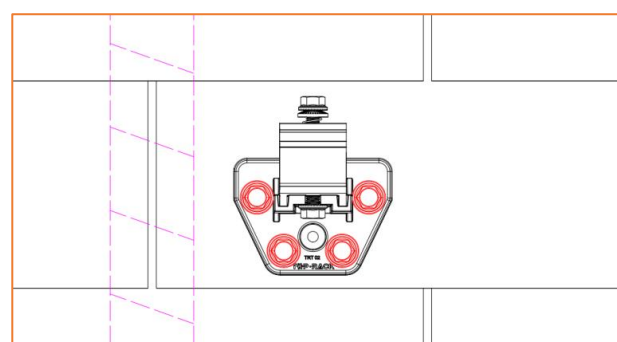

#### Install on deck

When the entire base on the deck, then 4 lag screws are required.

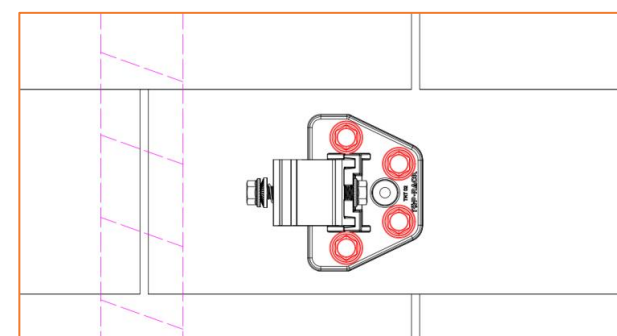

## Installing modules vertically

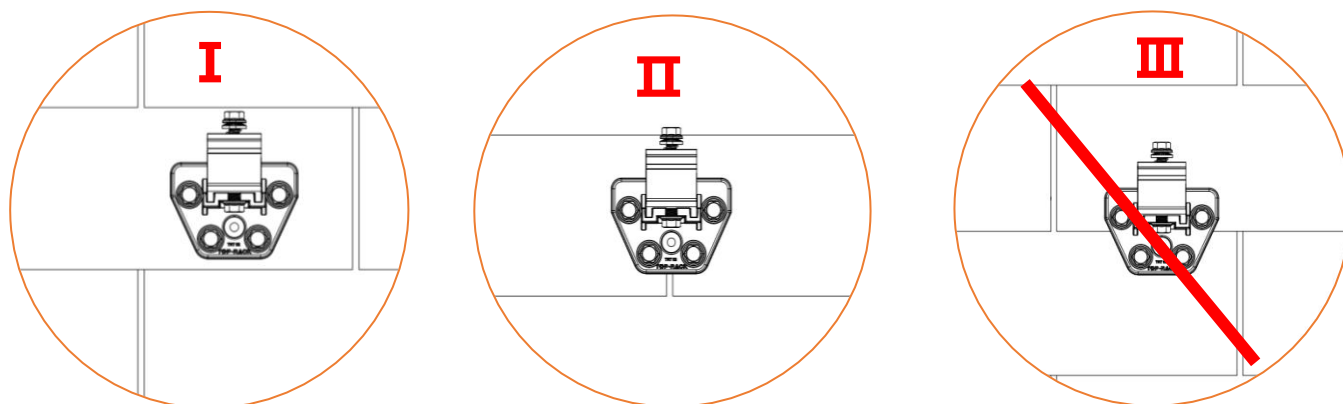

## Installing modules horizontally

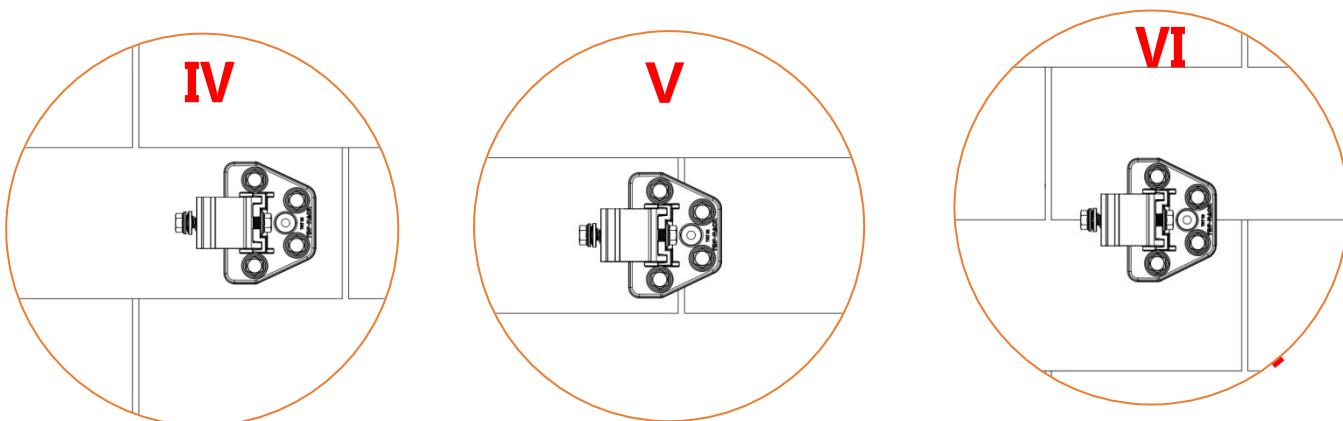

I & IV: when the bases installed on a single comp tile, no special impervious water treatment is required.

II & V: The base should be avoided to installed directly on the keyways of the shingle, if it is unavoidable, fill the keyways by a layer of approved sealant.

III & VI: It is not allowed to cross the upper and lower shingles installation base. If this happens, move the base mount to avoid this area. within a maximum up and down movement range of 5".



## 6.2 Installation of base

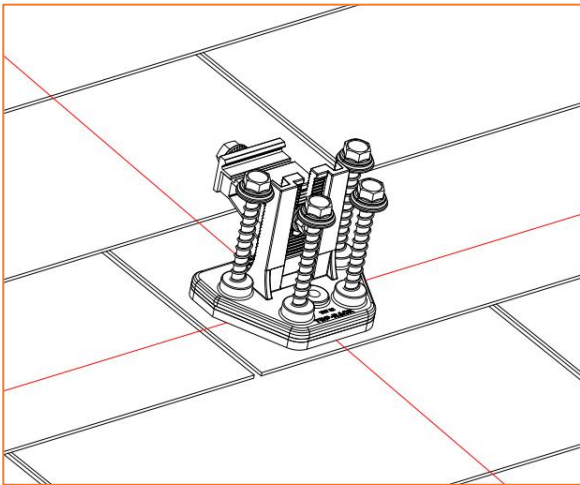

② Remove the release liner of the butyl adhesive on the base, then stick the base on the planned mounting points, press gently to make the butyl adhesive adhere to the roof. Be careful to apply force evenly when pressing and do not tilt the base.

The lag screws have been pre-assembly on the base but have not yet tightened.

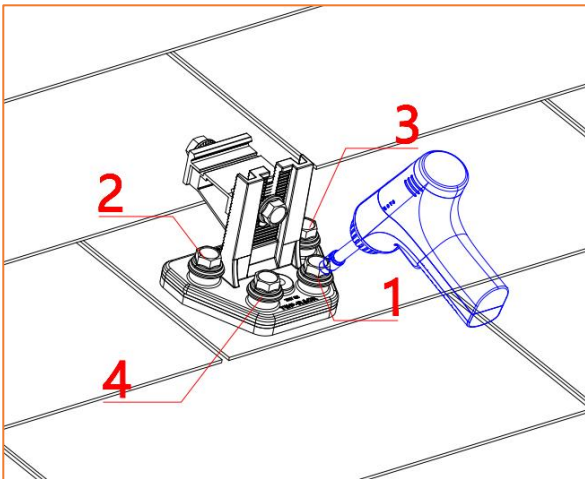

Note: When install 4 lag screws, the screws must be installed in diagonal order, by 1/2" socket.

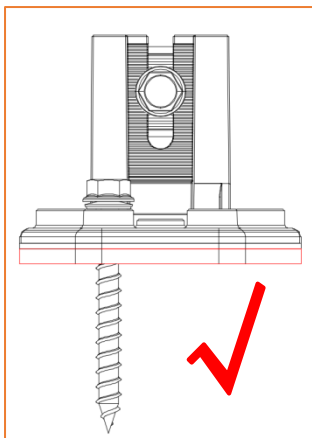

Correct Torque

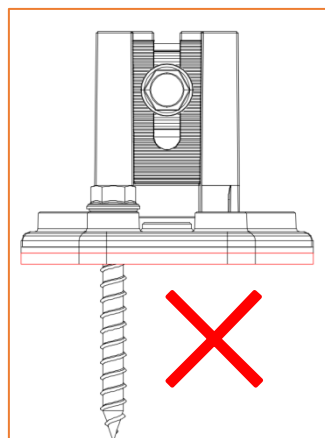

Too much Torque

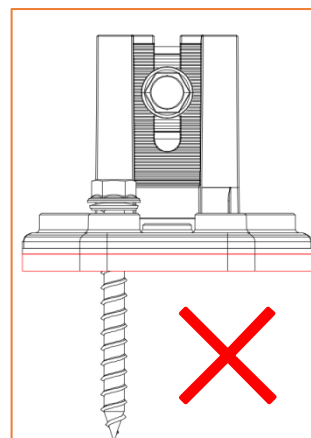

Not enough Torque

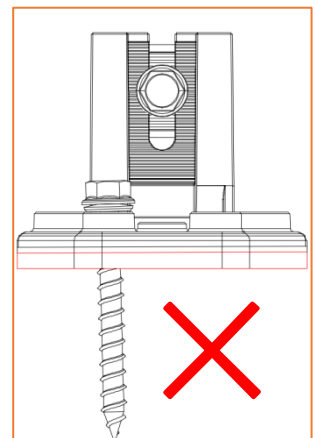

Tilted



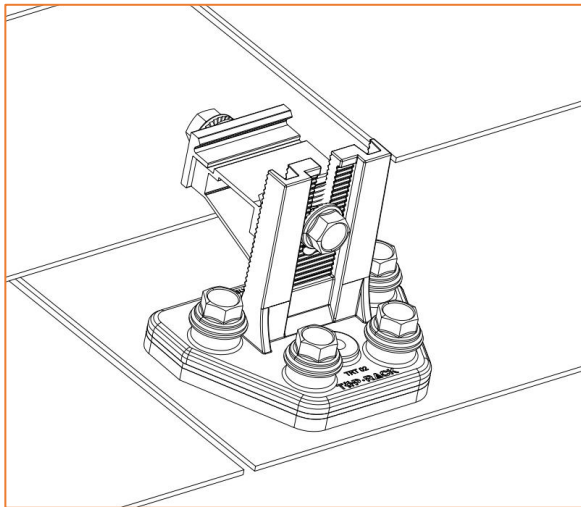

③ Due to the aging of the roof, the roof surface may be uneven. The installation height of the rail fastener can be adjusted up and down. The rail fastener has been pre-assembled on the base.

Note: The maximum height of the base is 2.7" and the minimum height is 1.96".

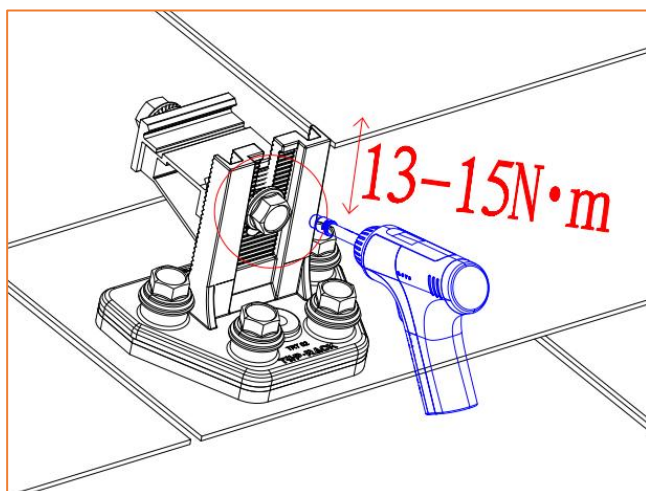
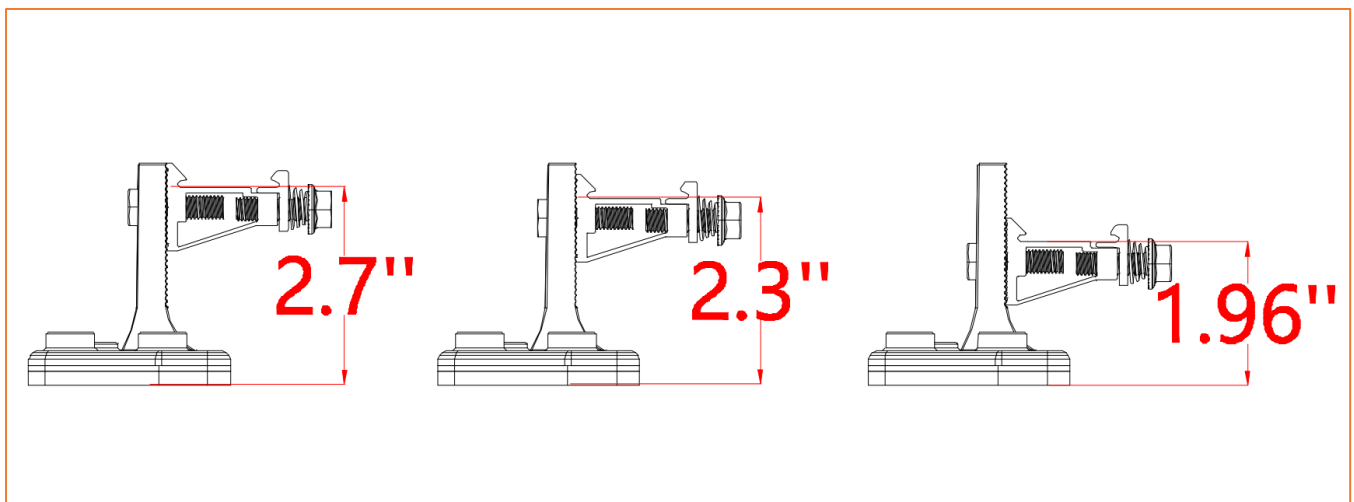

④ Secure the bolt of the rail fastener on the base by 1/2" socket with torque 13~15N.m



Check to make sure the rail fasteners are at the same level.

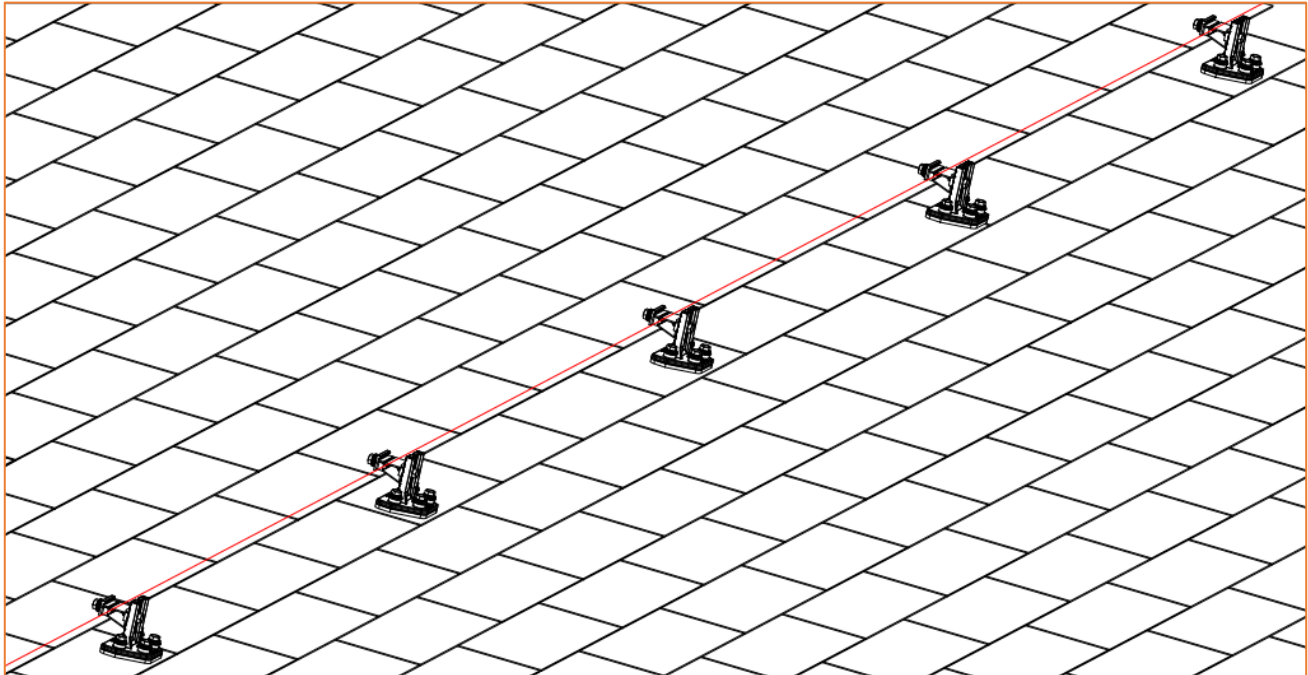

## 6.3 Installation of the solar mount rail

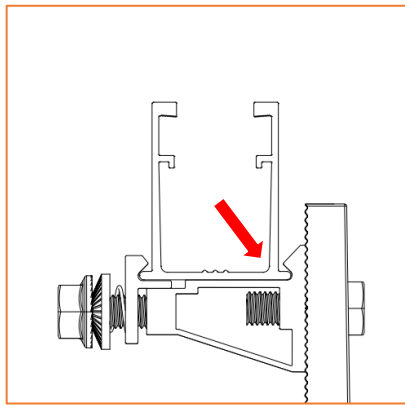
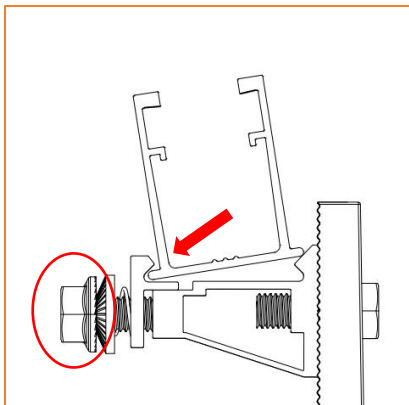

- ⑤ Slightly loosen the bolts of the rail fastener, then tilt the rail and push it into one slot of the rail fastener. Push the rail into the slot on the other side of the fastener.



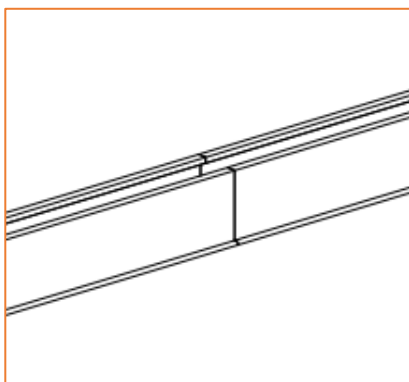
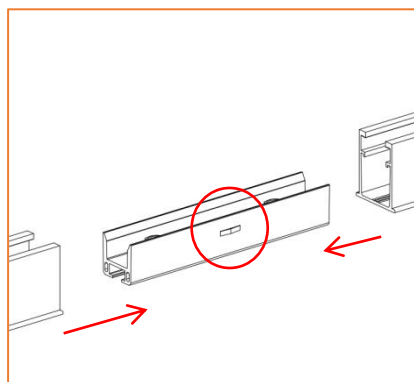

⑥ If rail splice is necessary during the installation, then connect the rails before mounting it on the rail fastener. Insert the rail splice into the two end of rails until reach the anchor point.

Tighten the bolts of the rail splice by 1/2" socket with torque 13~15N.m

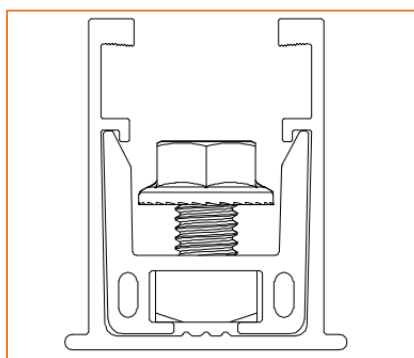
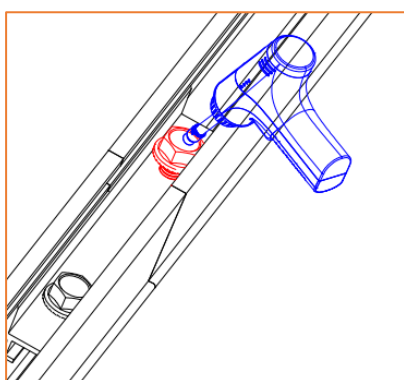
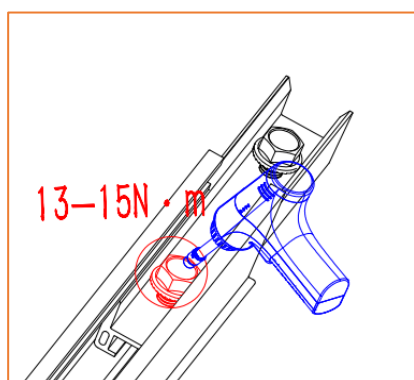

Before tighten bolts

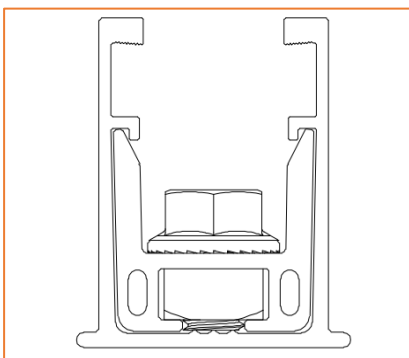

After tighten bolts

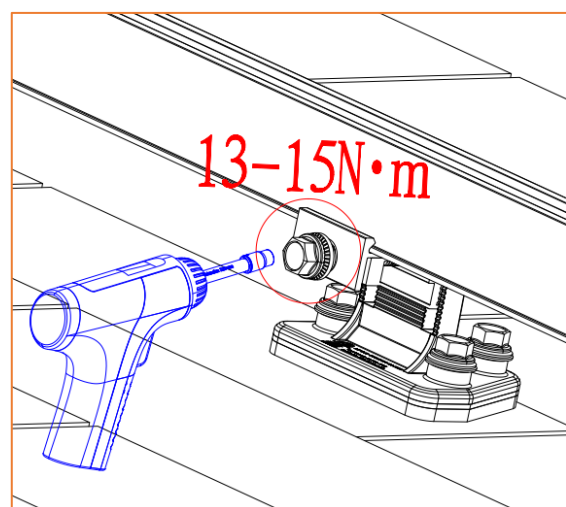

⑦ Adjust the rail to a suitable position, tighten the bolts on the of rail fastener by 1/2" socket or wrench with torque 13~15N.m

Note: The longest mounting length of the rail is 30m



## Optional installation (wire management)

For horizontal cable management, insert the cable into the rail cavity along the direction of the guide, and cover the cable cap.

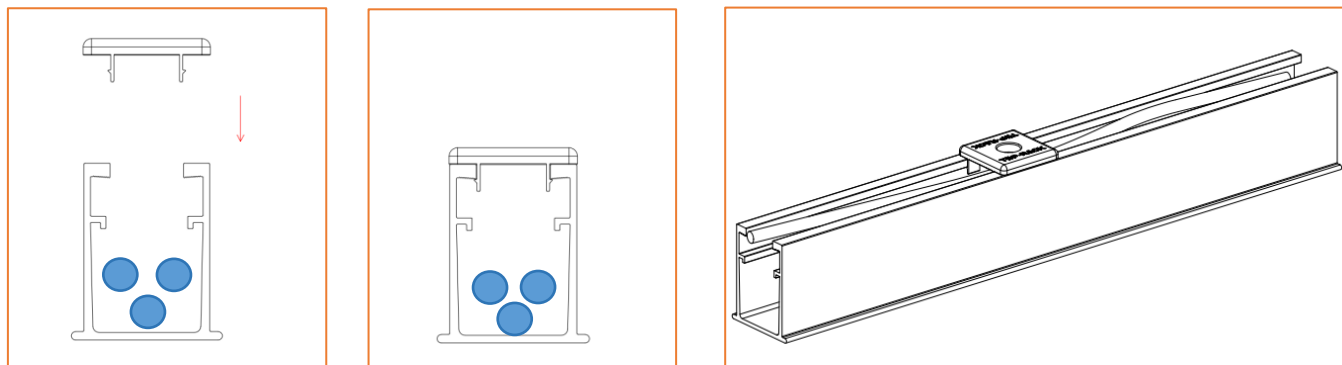

## 6.4 Installation of the solar pane

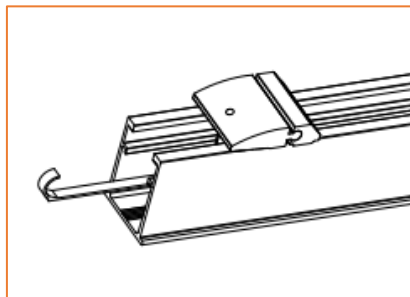
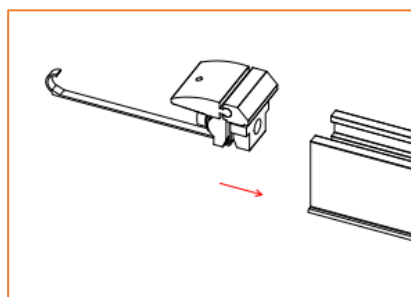

⑧ Sliding the hidden end clamp into the rail. Place the solar module on the rail over the end clamp. Pull the tie of the hidden end clamp to press against the module frame. continuing pulling the tie til the edge of the module frame is flush with the edge of the rail. Tighten the bolt by 1/2'' socket to secure the hidden end clamp. The Torque is 13~15 N.m.

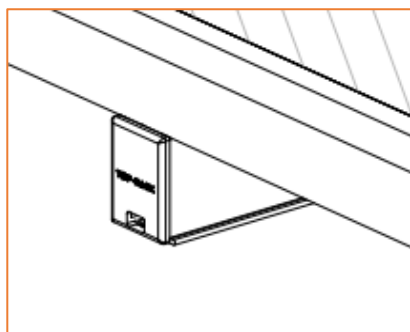
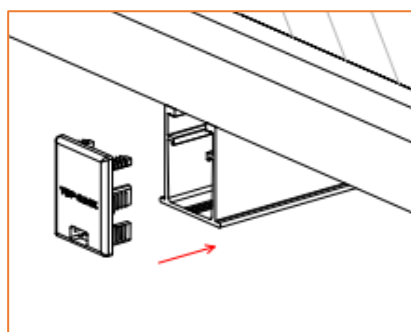
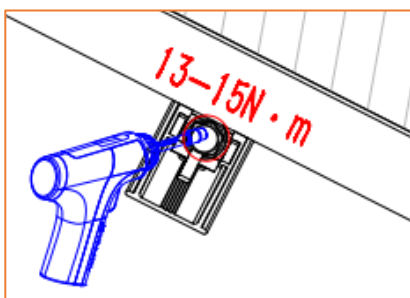
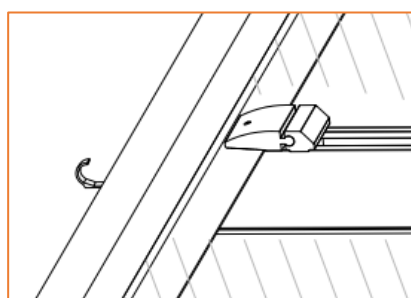

⑨ Insert the exposed tie into the channel, then cover the rail end by the end cap.



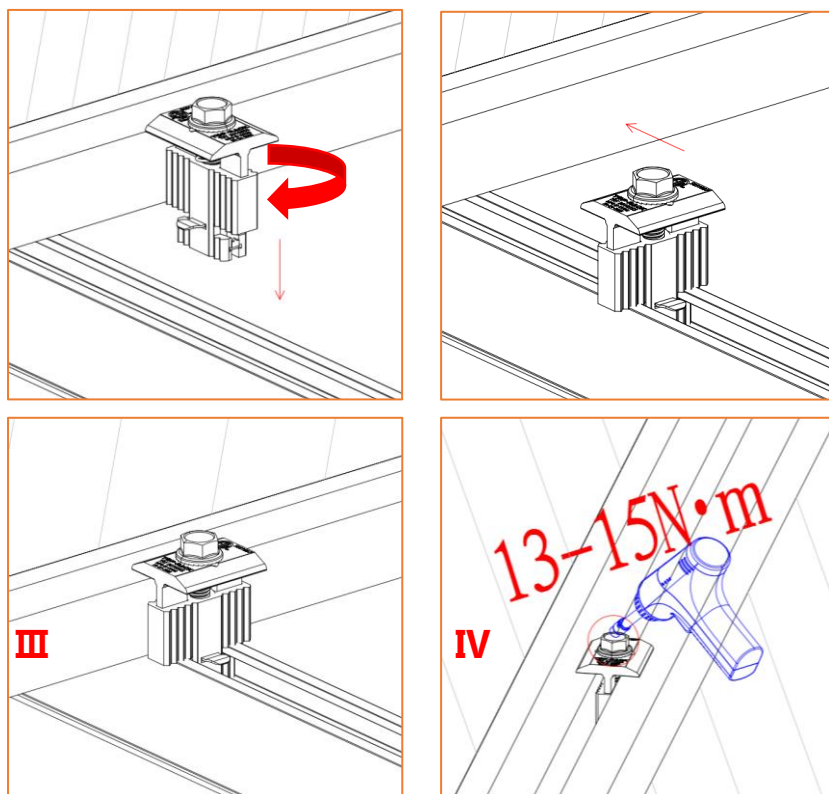

⑩ Insert the mid clamp into the rail as the direction of the panel clamp, rotate the middle clamp by 90°, slide the mid clamp until it compresses the frame of the solar modules.

⑪ Place another solar module on the rail, press it by another side of the mid clamp, adjust the module then using 1/2" socket or wrench to secure the bolt of mid clamp. The torque of the bolt is 13~15N.m

Note: The grounding nail of the mid clamp must press on the frame.

Note: The mid clamp can fits panel thickness from 30~40mm.

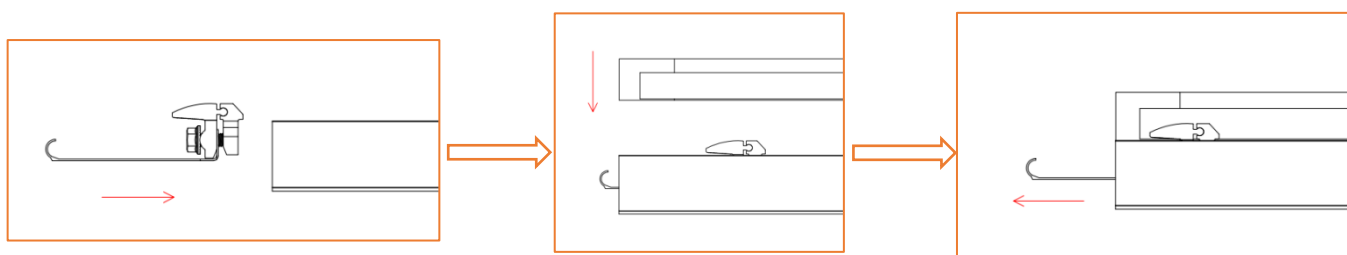
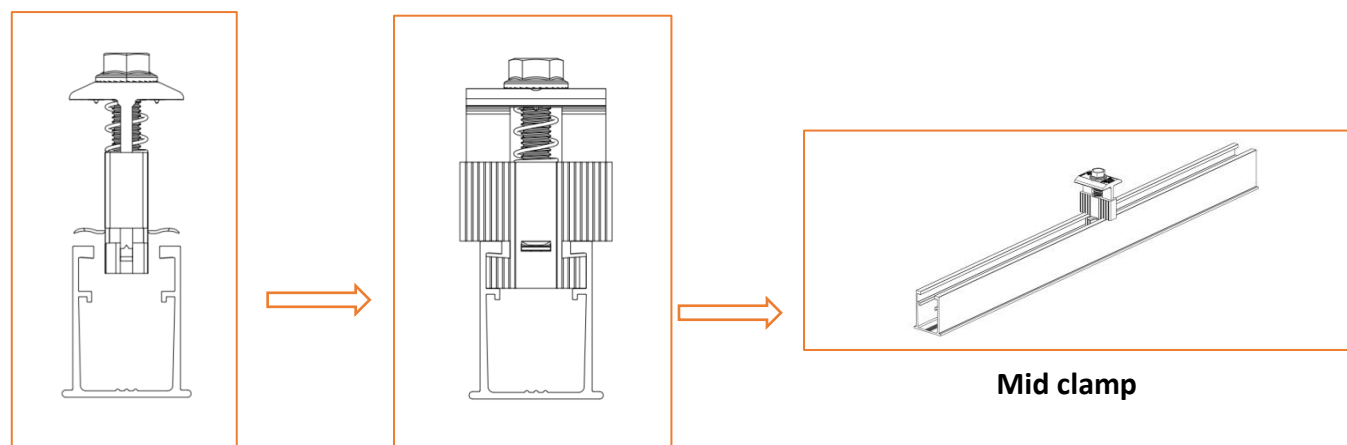

## 6.5 Install the skirt

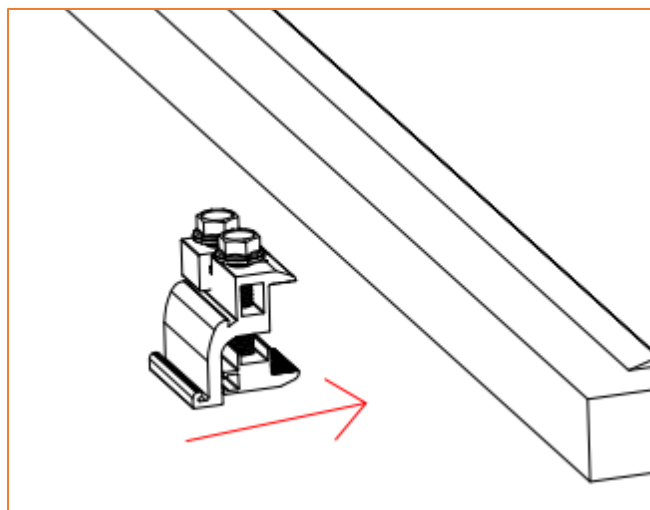

⑫ Assembly the skirt fastener clip on the frame of first row of solar panel, the skirt fastener can be used on the frame thickness from 30~40mm.

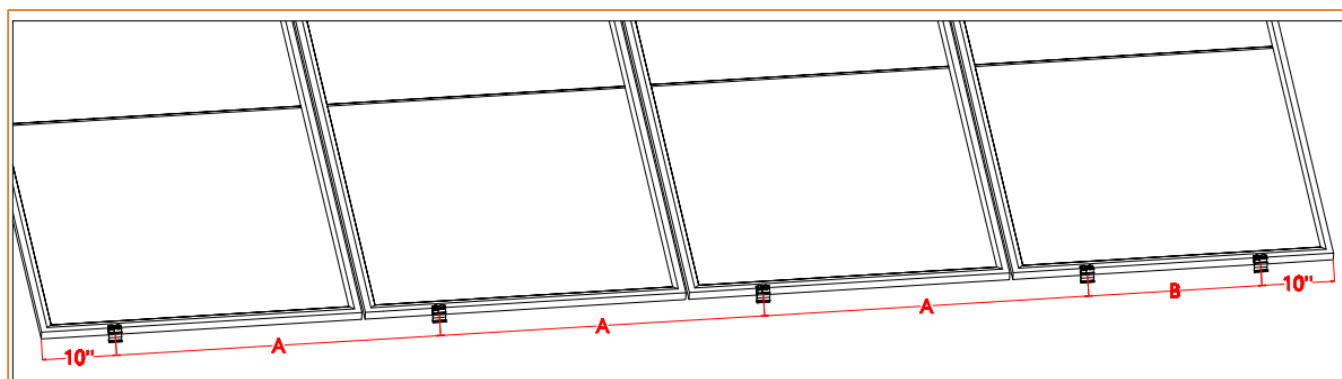

⑬ Adjust the position of the skirt clips, the distance from both ends of the panel to the nearest skirt clip is 10". The space of other skirt clips is at most the width of the panel, which can be decreased if needed, such as Case B.

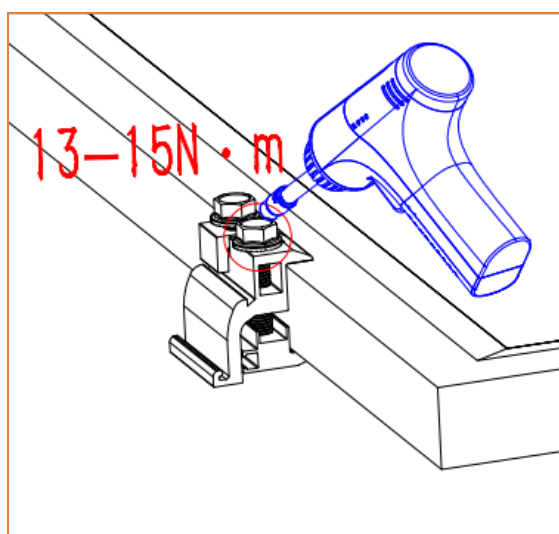

⑭ Secure the right bolt by 1/2" socket to prevent the clip from loosening and moving. The torque is 13~15N.m



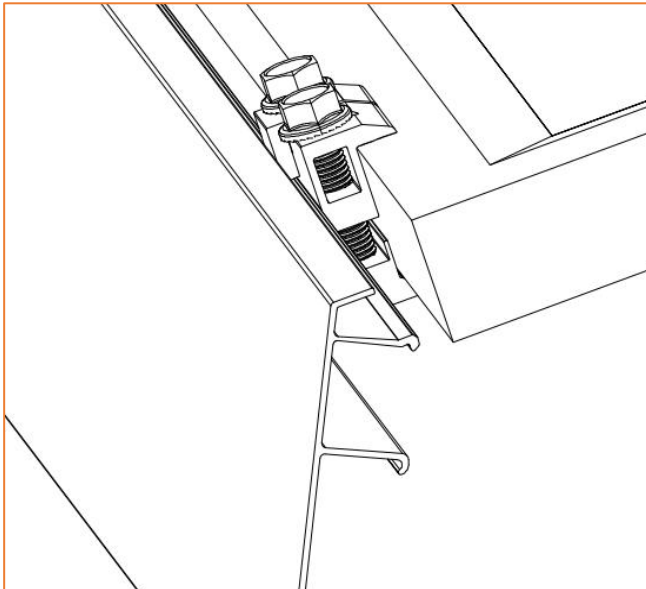
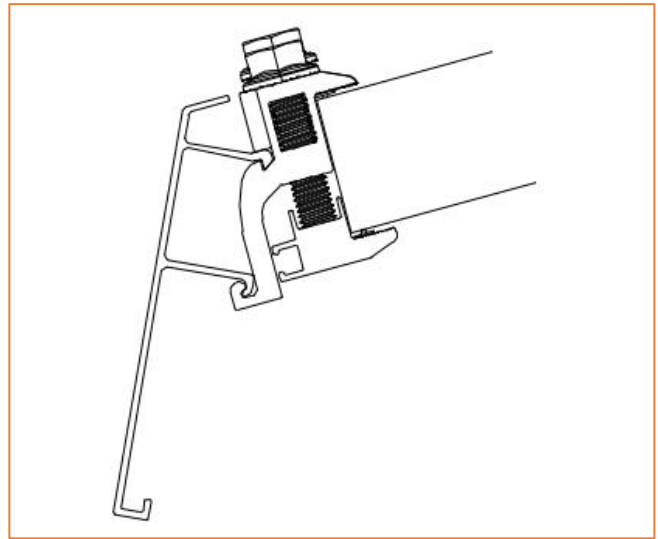
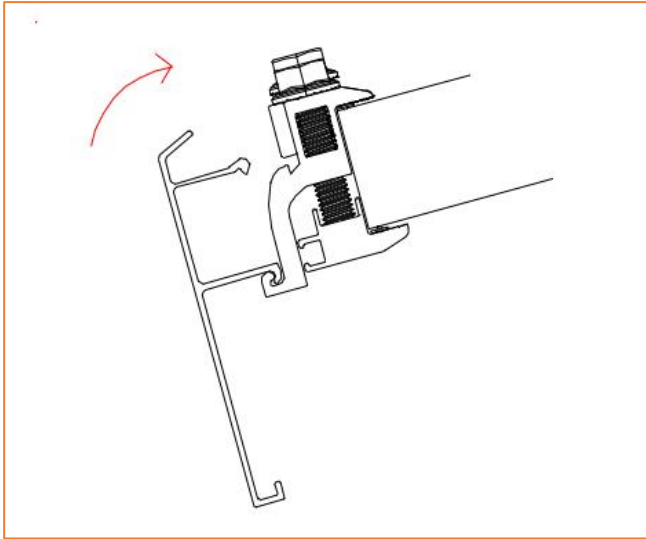

⑮ Tilt the skirt so that the central buckle fits perfectly with the bayonet at the lower end of the fastener.

Tilt the skirt again and buckle its upper end into the upper end of the fastener.

**Note:** Keep the middle buckle from sliding out when installing the upper buckle



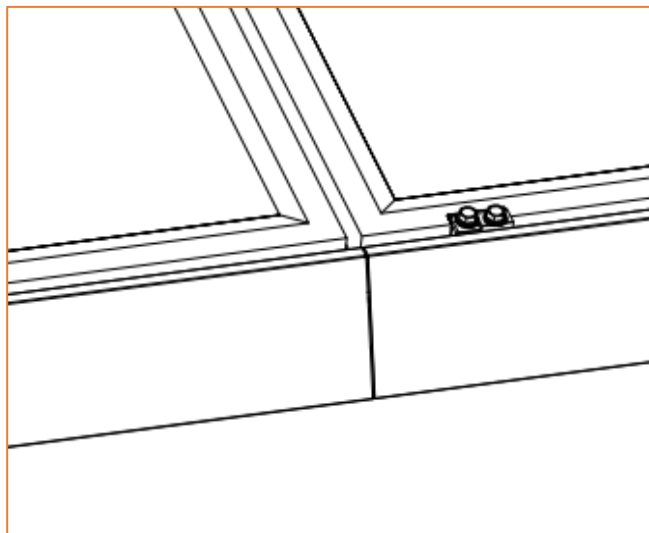
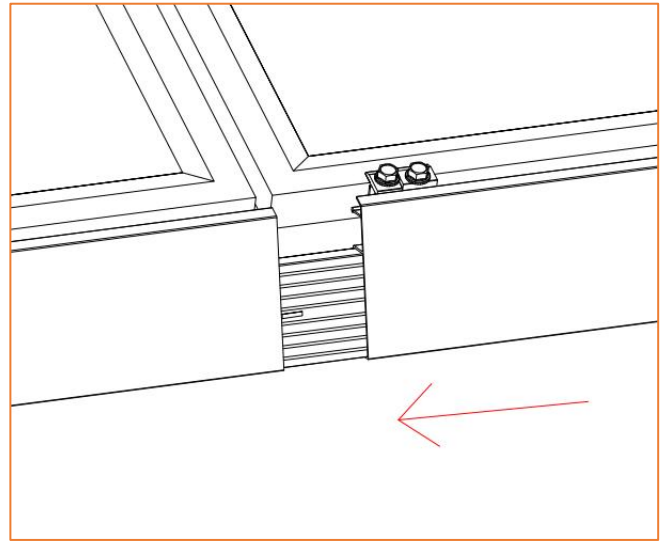
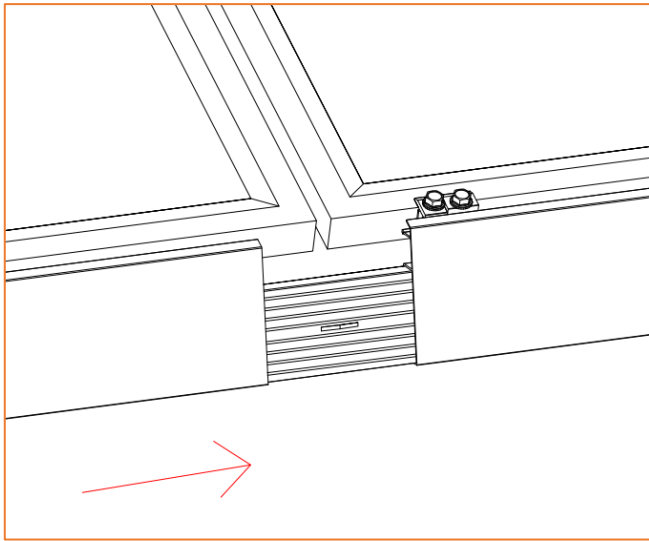

⑩ Adjust the Skirt front of each panel, connect the two adjacent skirts with connectors.

Note: Insert the connector to the skirt channel until it reaches the anchor point.

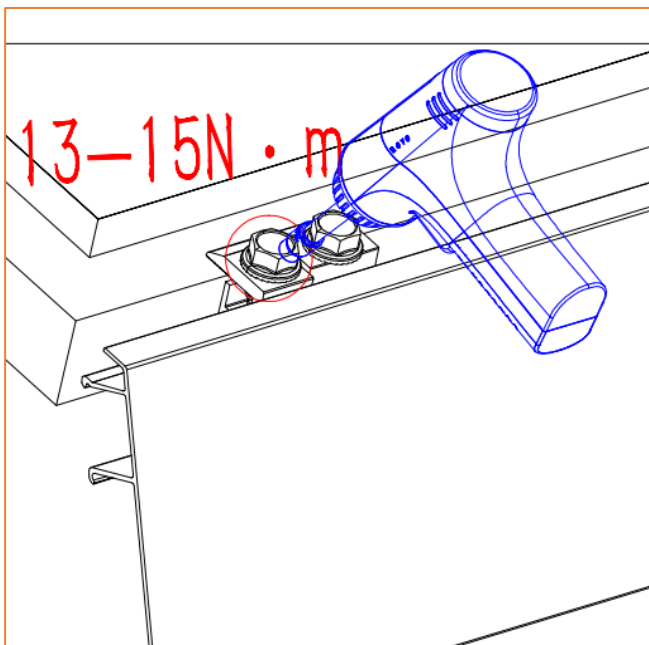

⑪ Secure the left bolt by 1/2" socket to ensure the skirt cannot be move anymore. The torque is 13-15N.m



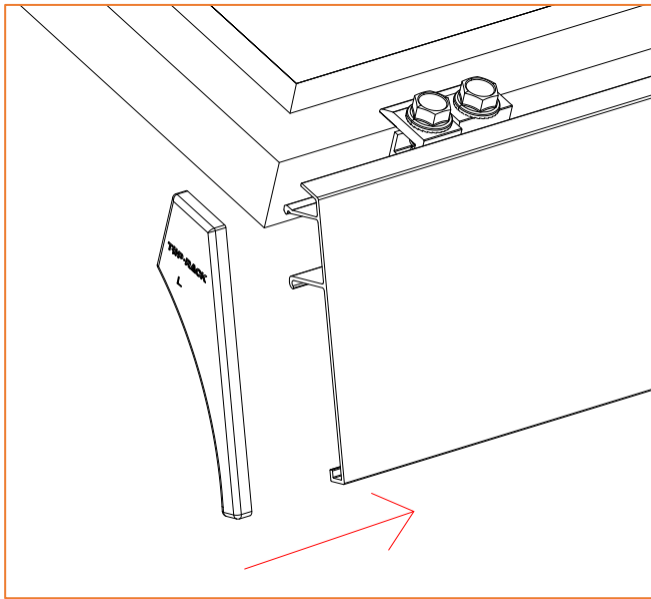

⑱ Cover two ends of the skirt with the end cap.

Note: The end cover needs to be distinguished from the left and the right.

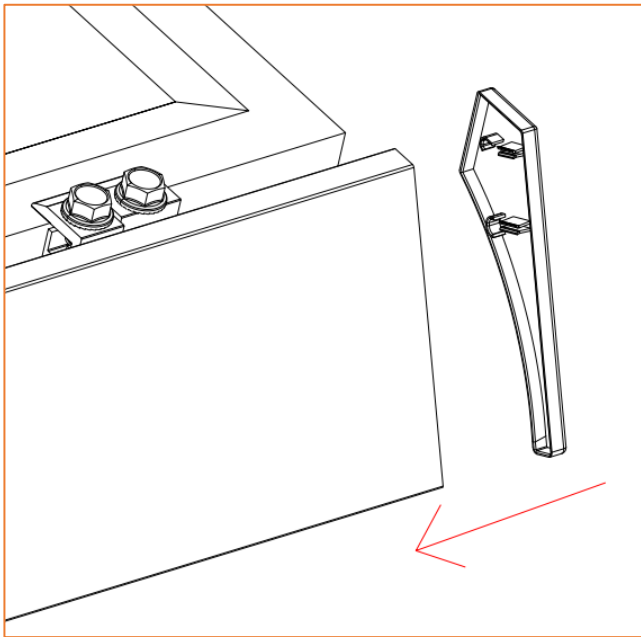

Note: When installing the end cap, be sure of the direction.

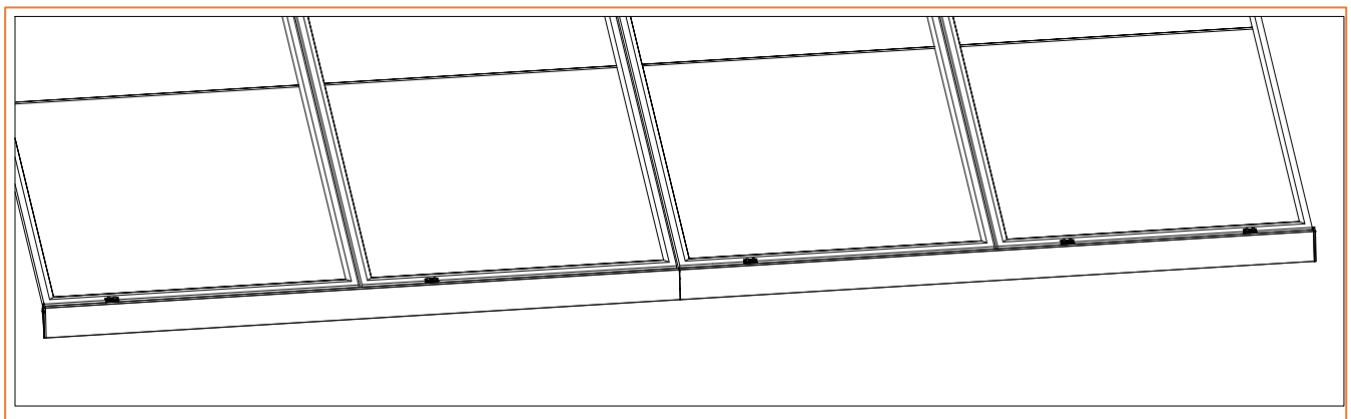

## 6.6 Installation of grounding lug and bonding jumper

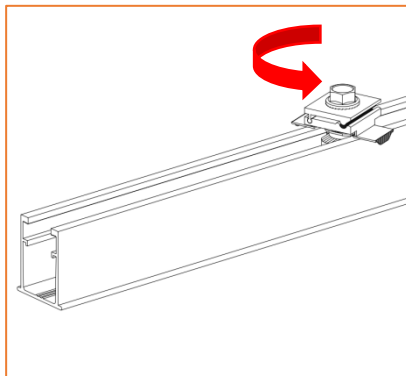
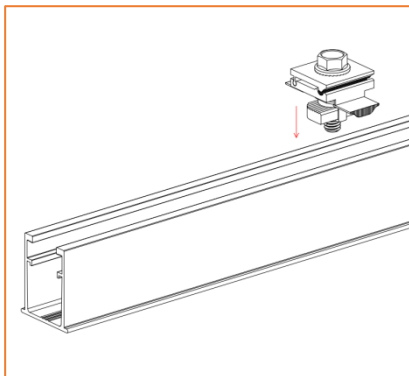

⑲ Push the nut of the grounding lug into the rail channel, turn the nut 90 degrees to lock it into the rail.

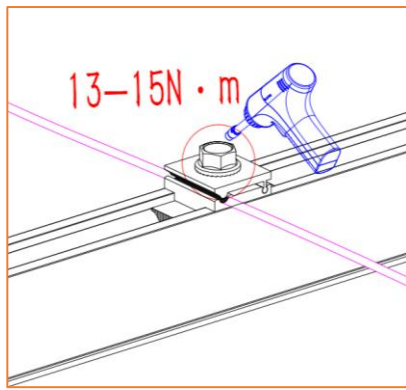
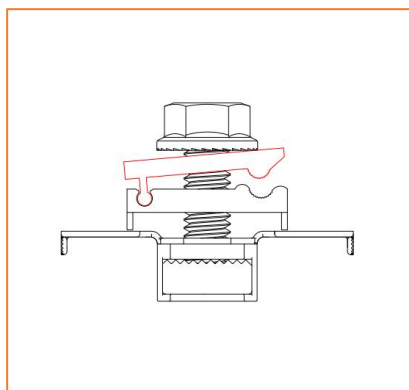

⑳ Place the grounding wire in the slot of the grounding lug. Tighten the bolt by 1/2" Socket i with torque 13~15N.m

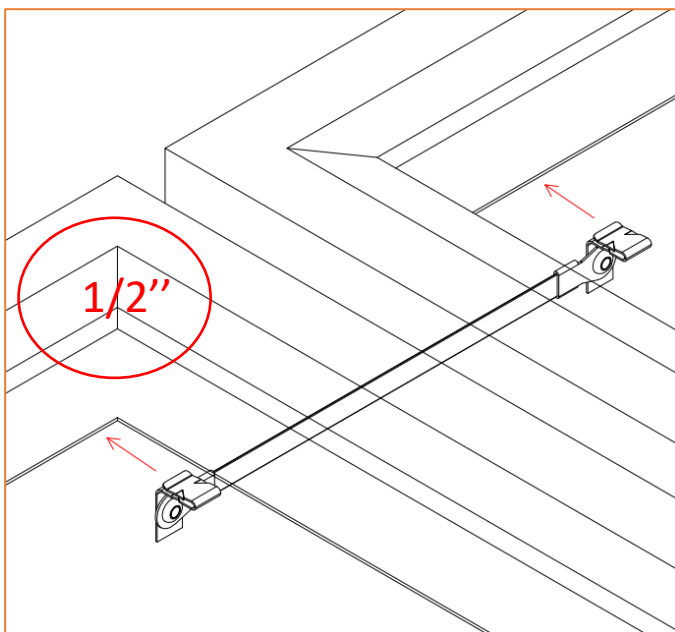

㉑ Using bonding jumper to connect the upper and lower row of panel, the teeth of the clip on bonding jumper pierced the oxide film on the aluminum frame.

Note: The space between the upper row and lower row of solar panel is 1/2''



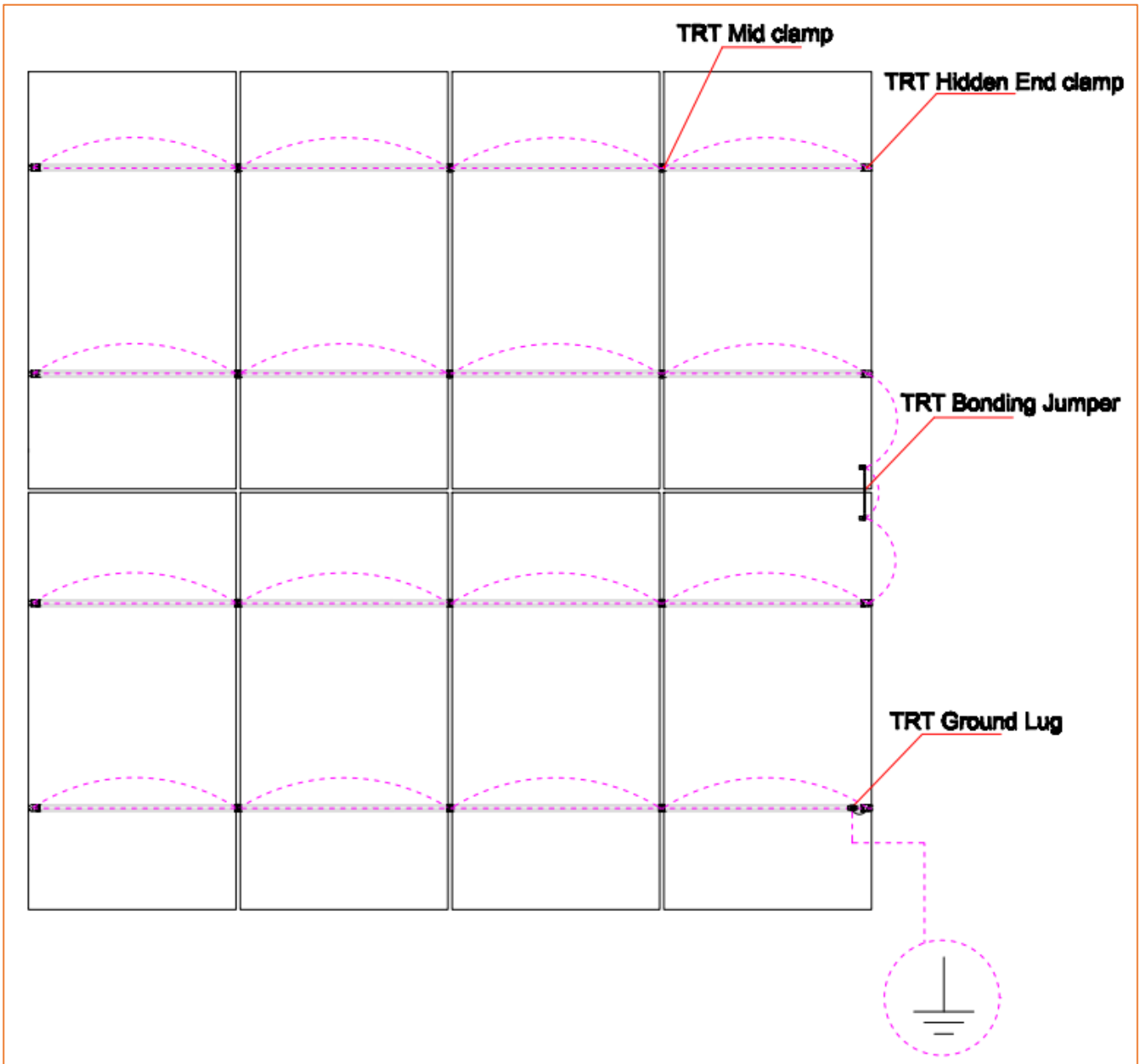

## 6.7 Installation of micro inverter

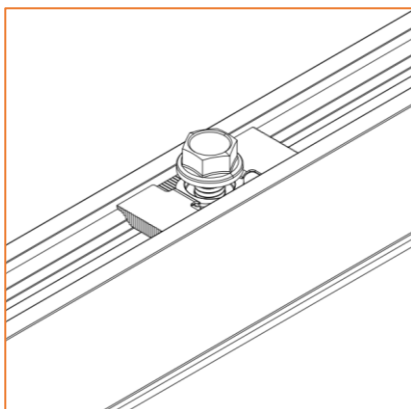
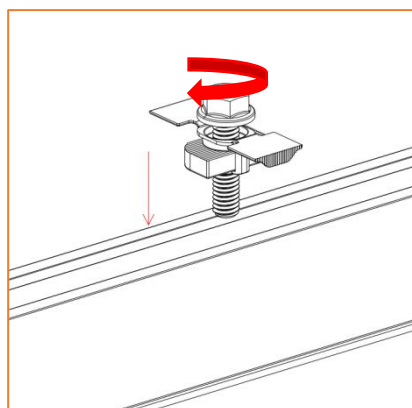

② Push the nut of the Micro inverter racking into the rail channel, turn the nut 90 degrees to lock it into the rail.

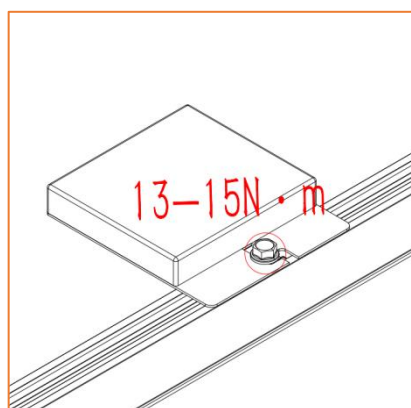
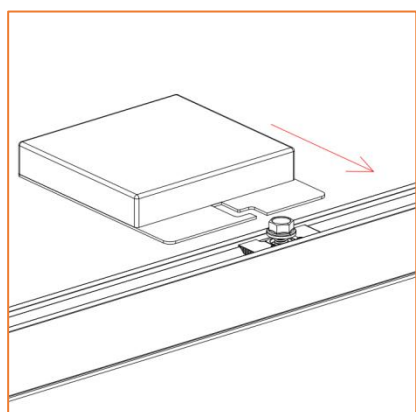

③ Slide the micro inverter until it is under the flange nut. Tighten the bolt by 1/2" socket with a torque of 13~15N.m.



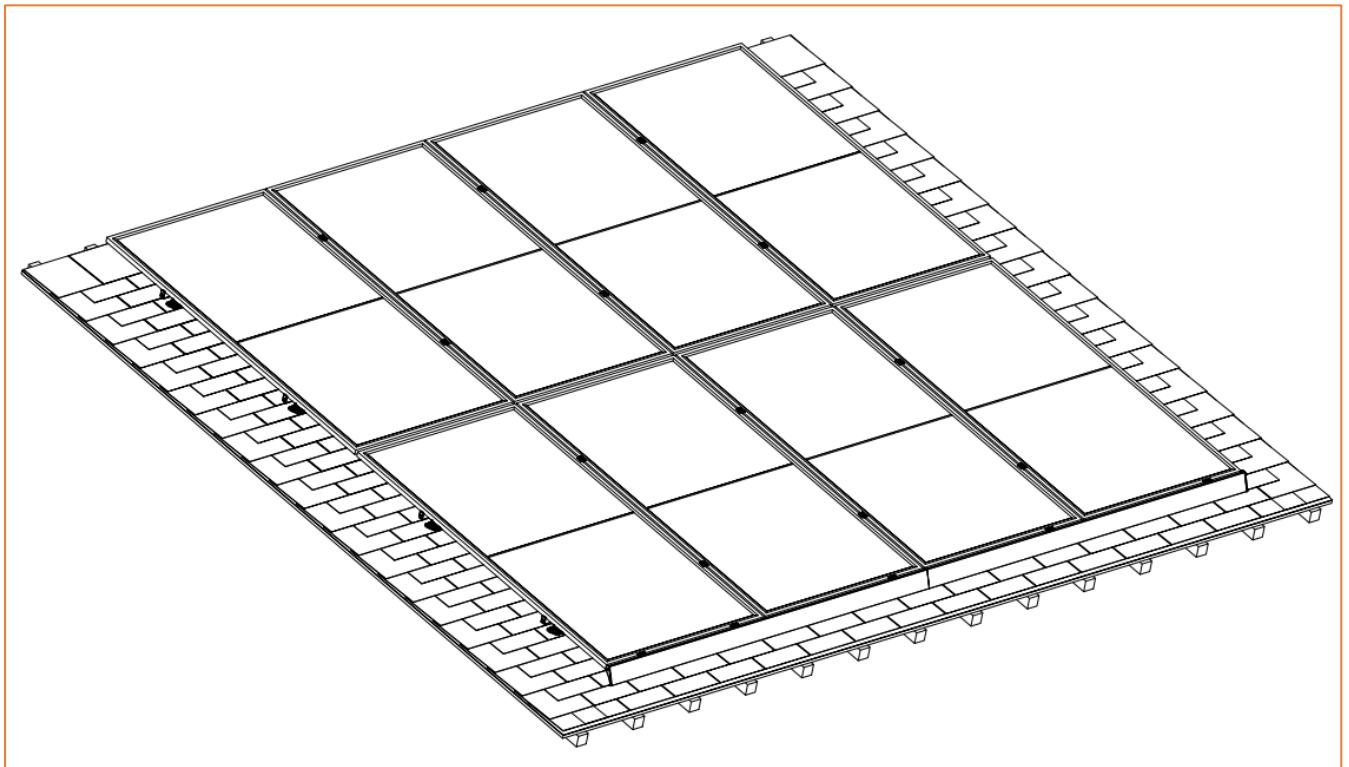
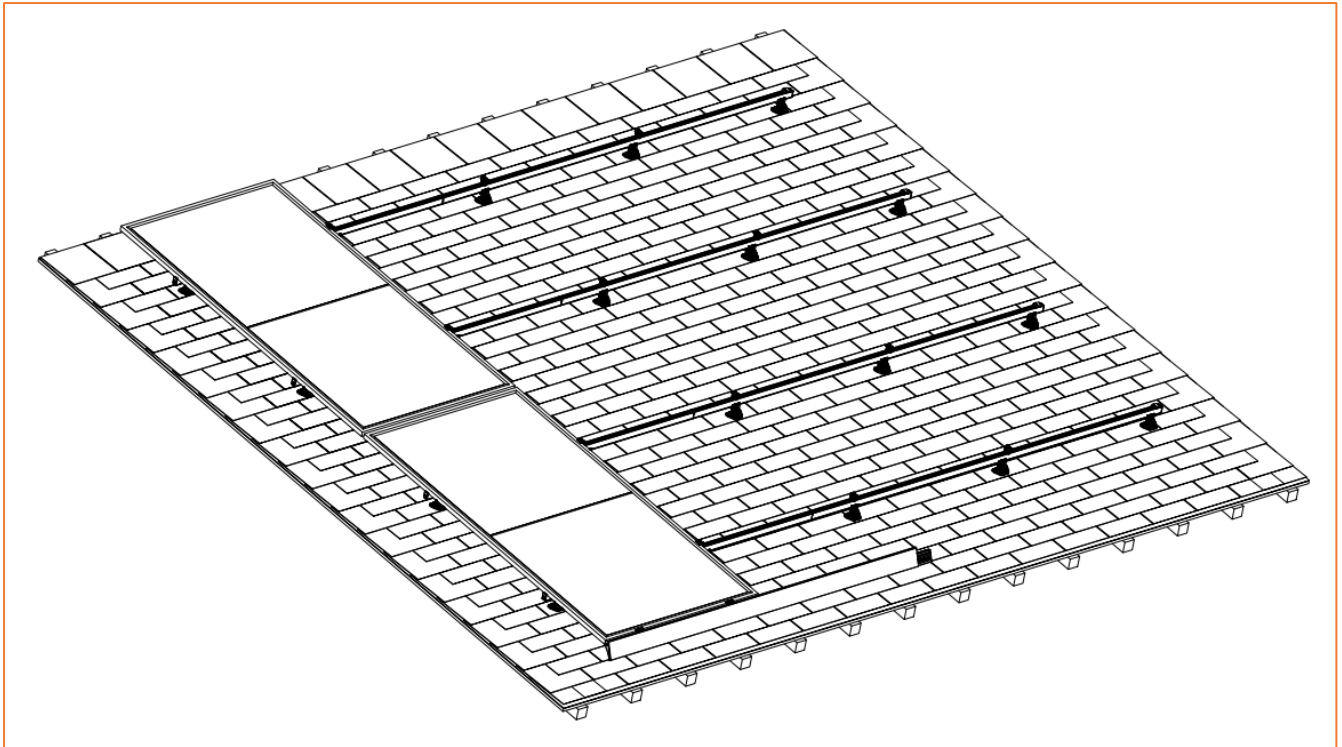

## Thank you!

Top Rack Technology, Inc.

Email: [info@topracktech.com](mailto:info@topracktech.com)

Phone: 888 575 7818

©Top Rack Technology, Inc. Copyright 2024 All rights reserved. The content is protected by copyright law. Top Rack Technology, Inc. reserves the right to modify, update, or amend the content without prior notice.

